

INVENT YOUR OWN TOOL...

...which can be built onto the HL unit,
and benefit from over
6 tonnes of force from the trigger.

cut
shear
twist
pull out
crimp
join
force
separate

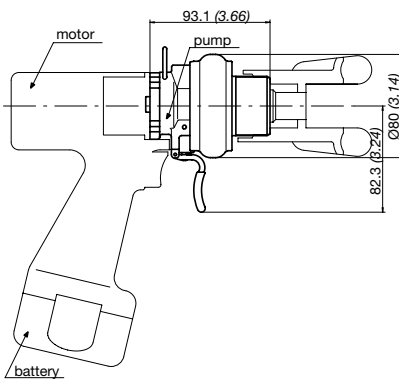

The micro-pump / motor is a fixed displacement, high pressure unit, designed as the power unit for battery driven handtools requiring great force. The pump is designed for direct integration onto widely available tools. The interface on the tool head side is adapted to suit each different application.

Rated speed: 2000rpm
Displacement: 0.0048cu.in/rev (80mm³/rev)
Maximum pressure: 7970PSI (550bar)
Supply current: 12V